



EC DECLARATION OF CONFORMITY

WE:

POLAR TOOLS A/S
Soldalen 9, DK-7100 Vejle, Denmark

Declare in sole responsibility that the equipment

EQUIPMENT: GRINDER - STRAIGHT

MODEL/SERIAL NO.: 6110-0000

to which this declaration applies, complies with these normative documents:

MACHINERY DIRECTIVE: 2006/42/EC

and conforms to the following EN standards,

EN ISO 12100:2010
EN ISO 11148-6:2010

Authorized representative established within the EU (if applicable):

Company Name: Polar Tools A/S

Company Address: Soldalen 9, DK-7100 Vejle, Denmark

Person responsible for compiling the technical file established within the EU:

Name, Surname: Mikael Linde

Address: Jens Grøns Vej 1, DK-7100 Vejle, Denmark

Note: This declaration becomes invalid, if technical or operational modifications are introduced without the manufacturers consent.

Name and Signature/Position Title

Date and place

Mikael Linde, Owner

Denmark, January 10, 2013



Read the operator's instructions before operating the tool.



Wear eye protection device.



Wear ear protection device.

OPERATING INSTRUCTIONS



IMPORTANT

Read these instructions carefully before installing, operating, servicing or repairing this tool. Keep these instructions in a safe accessible place.

MANUFACTURER/SUPPLIER

Polar Tools A/S
Soldalen 9 · DK-7100 Vejle · Denmark
Tel: +45 7584 1122
E-mail: info@polartools.com · www.polartools.com

PRODUCT TYPE
1/4" GRINDER - STRAIGHT

MODEL
6110-0000



Actual product may be slightly different from the product described here in.

SAFETY RULES

Read, understand and keep these instructions!



WARNING

Failure to follow all instructions listed below may result in serious injury.

WORK AREA HAZARD & PERSONAL SAFETY

1. Keep your work area clean and well lit.
2. Do not operate power tools in explosive atmospheres, such as in the presence of combustible liquid, gases or dust. Power tools create sparks which may ignite the dust or fumes.
3. Disconnect tool before performing service or when not in use.
4. High sound levels can cause permanent hearing loss. Use hearing protection during operation.
5. Maintain a balanced body position and secure footing.
6. Slips/Trips/Falls are a major cause of serious injury or death. Be aware of excess hose left on the working floor.
7. Repetitive work motions, awkward positions and exposure to vibration can be harmful to hands and arms. If numbness, tingling, pain or whitening of the skin occurs, stop using the tool and consult a physician.

8. Always wear impact-resistant eye and face protection when operating, repairing or performing maintenance of the tool or while changing tool accessories.

TOOL USE AND CARE

1. Use support handle or other method to secure and support the work piece to a stable platform.
2. Do not force the tool. Use the correct tool for your application. Using the correct tool which is specifically designed for a select job will provide better tool performance and make the job easier.
3. Disconnect the air supply before making any adjustments, changing accessories, or storing the tool. Always disconnect the air supply before performing any inspection, maintenance or tool cleaning.
4. Use only accessories recommended by the manufacturer for your model.
5. When using a tool that is designed to have a guard, the guard should be in place to provide protection from flying debris, grinding residue or sparks.
6. Do not leave the tool unattended when it is connected to an air supply.
7. Use compressed air only.

AIR SUPPLY SETUP AND CONNECTION

Recommended Air Line Components

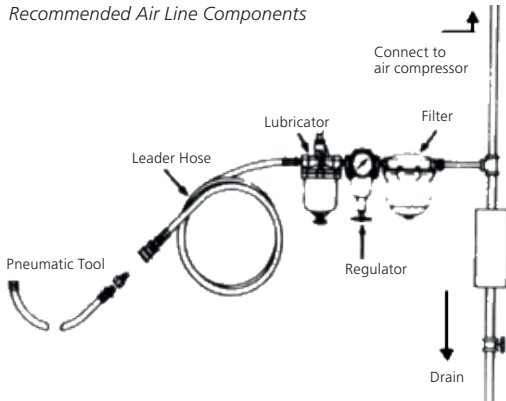

1. For optimal results you should incorporate a regulator, oiler and an inline filter.
2. If you are not using an automatic lubricating system, before operating the tool, add a few drops of Pneumatic Tool Oil to the air-line connection. Add more after each hour of constant using.
3. Do not exceed maximum air pressure of 90 PSI/ 6,2 bar or as stated on tool nameplate.

OPERATING INSTRUCTIONS

Check the position of the reversing mechanism before operating the tool so as to be aware of the direction of rotation when operating.

Before switching on the tool, make sure that the grinding stone or rotating file is correctly assembled and properly tightened.

Assembly of the grinding stone/ rotating file: The die grinder must be disconnected from the compressed air supply.

Loosen the collet, then put the shank of grinding stone or rotating file in the collet as deep as possible.

Tighten it securely use the two wrenches included with the grinder.

LUBRICATION & MAINTENANCE

Lubricate the tool daily with a high grade of air tool oil. If no air line oiler is used, run a teaspoon of oil through the tool.

The oil can be squirted into the tool air inlet, or into the hose at the nearest connection to the air supply, prior to operating the tool.

A rust inhibitive oil is acceptable for air tools.

PARTS NO.

DESCRIPTION

P6110-0000-01	Motor Housing
P6110-0000-02	Lever Pin (3 x 18L)
P6110-0000-03	Air Inlet
P6110-0000-04	Throttle Lever
P6110-0000-05	Valve Shaft
P6110-0000-06	Deflector
P6110-0000-07	O-Ring (3) (7,5 x 1,5)
P6110-0000-08	Spring •
P6110-0000-09	O-Ring (9,8 x 1,9) •
P6110-0000-10	Valve Screw
P6110-0000-11	O-Ring (10,5 x 1) •
P6110-0000-12	Rotor Spacer
P6110-0000-13	Ball Bearing (696ZZ) •
P6110-0000-14	Rear End Plate
P6110-0000-15	Rotor
P6110-0000-16	Vane (4) •
P6110-0000-17	Spring Pin (2) (1,5 x 6)
P6110-0000-18	Cylinder
P6110-0000-19	Front End Plate
P6110-0000-20	Ball Bearing (608ZZ) •
P6110-0000-21	Spring Pin (2 x 15L)
P6110-0000-22	Spindle
P6110-0000-23	Front Coupling
P6110-0000-24	Collet
P6110-0000-25	Collet Nut
P6110-0000-26	Front Cap
P6110-0000-27	Spanner (2)
P6110-0000-28	Safety Bar
P6110-0000-29	Fixed Shaft
P6110-0000-30	Steel Ball (3/32")
P6110-0000-31	Steel Ball (1/8")
P6110-0000-32	O-Ring (3,8 x 1,9) •
P6110-0000-33	Grip
P6110-0000-34	Bushing
P6110-0000-35	O-Ring (20 x 1,4) •
P6110-0000-36	Spring
P6110-0000-37	Throttle Valve
P6110-0000-38	Washer
P6110-0000-39	Damping Material
P6110-0000-50	• Service Kit

1/4" GRINDER - STRAIGHT

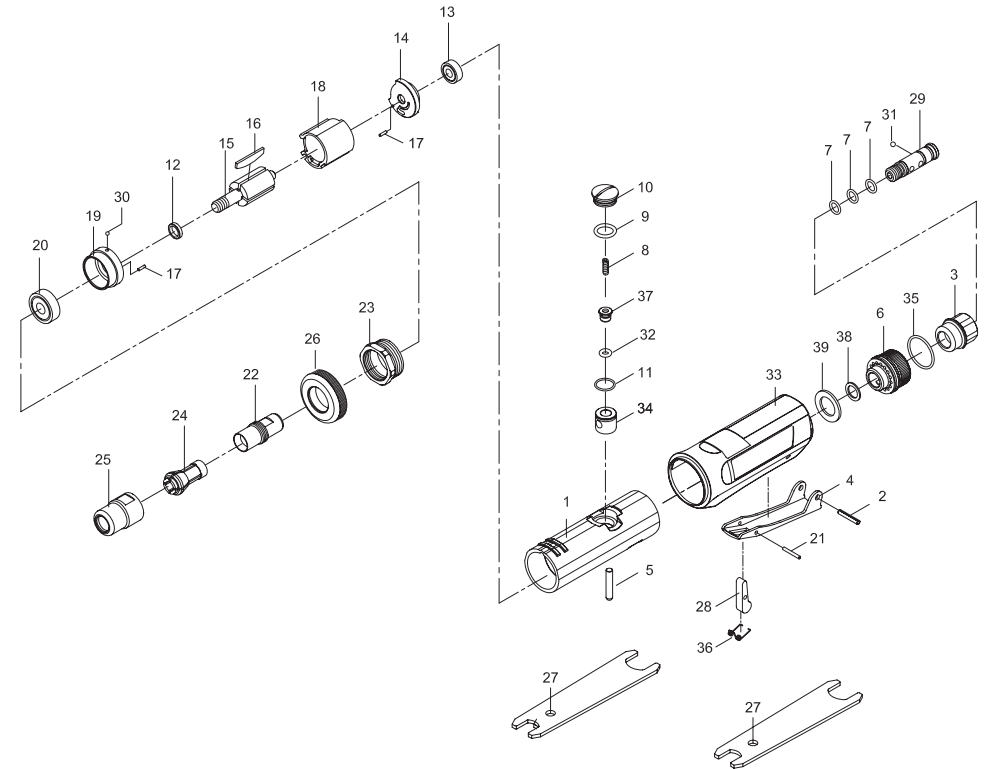

TECHNICAL SPECIFICATION

PRODUCT TYPE		MODEL: 6110-0000	
1/4" Grinder - Straight			
FREE SPEED	25.000 RPM	HOSE SIZE: 3/8" (10 mm)	WEIGHT: 0,4 Kg
COLLET SIZE:	1/4" (6 mm)	AIR PRESSURE: 6,2 Bar (90 P.S.I.)	
AIR INLET: 1/4" NPT		AVERAGE AIR CONSUMPTION: 113 L/Min (4 CFM)	