



EC DECLARATION OF CONFORMITY

WE:

POLAR TOOLS A/S
Soldalen 9, DK-7100 Vejle, Denmark

Declare in sole responsibility that the equipment

EQUIPMENT: EXTENDED DIE GRINDER

MODEL/SERIAL NO.: 6110-1100

to which this declaration applies, complies with these normative documents:

MACHINERY DIRECTIVE: 2006/42/EC

and conforms to the following EN standards,

EN ISO 12100:2010
EN ISO 11148-6:2012

Authorized representative established within the EU (if applicable):

Company Name: Polar Tools A/S

Company Address: Soldalen 9, DK-7100 Vejle, Denmark

Person responsible for compiling the technical file established within the EU:

Name, Surname: Mikael Linde

Address: Jens Grøns Vej 1, DK-7100 Vejle, Denmark

Note: This declaration becomes invalid, if technical or operational modifications are introduced without the manufacturers consent.

Name and Signature/Position Title

Date and place

Mikael Linde, Owner

Denmark, March 15, 2016



Read the operator's instructions before operating the tool.



Wear eye protection device.



Wear ear protection device.

OPERATING INSTRUCTIONS



IMPORTANT

Read these instructions carefully before installing, operating, servicing or repairing this tool. Keep these instructions in a safe accessible place.

MANUFACTURER/SUPPLIER

Polar Tools A/S
Soldalen 9 · DK-7100 Vejle · Denmark
Tel: +45 7584 1122
E-mail: info@polartools.com · www.polartools.com

PRODUCT TYPE
EXTENDED DIE GRINDER

MODEL
6110-1100



Actual product may be slightly different from the product described here in.

SAFETY RULES

Read, understand and keep these instructions!



WARNING

Failure to follow all instructions listed below may result in serious injury.

WORK AREA HAZARD & PERSONAL SAFETY

1. Keep your work area clean and well lit.
2. Do not operate power tools in explosive atmospheres, such as in the presence of combustible liquid, gases or dust. Power tools create sparks which may ignite the dust or fumes.
3. Disconnect tool before performing service or when not in use.
4. High sound levels can cause permanent hearing loss. Use hearing protection during operation.
5. Maintain a balanced body position and secure footing.
6. Slips/Trips/Falls are a major cause of serious injury or death. Be aware of excess hose left on the working floor.
7. Repetitive work motions, awkward positions and exposure to vibration can be harmful to hands and arms. If numbness, tingling, pain or whitening of the skin occurs, stop using the tool and consult a physician.

8. Always wear impact-resistant eye and face protection when operating, repairing or performing maintenance of the tool or while changing tool accessories.

TOOL USE AND CARE

1. Use support handle or other method to secure and support the work piece to a stable platform.
2. Do not force the tool. Use the correct tool for your application. Using the correct tool which is specifically designed for a select job will provide better tool performance and make the job easier.
3. Disconnect the air supply before making any adjustments, changing accessories, or storing the tool. Always disconnect the air supply before performing any inspection, maintenance or tool cleaning.
4. Use only accessories recommended by the manufacturer for your model.
5. When using a tool that is designed to have a guard, the guard should be in place to provide protection from flying debris, grinding residue or sparks.
6. Do not leave the tool unattended when it is connected to an air supply.
7. Use compressed air only.

AIR SUPPLY SETUP AND CONNECTION

Recommended Air Line Components

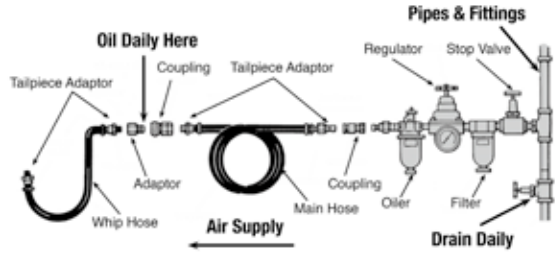

- For optimal results you should incorporate a regulator, oiler and an inline filter.
- If you are not using an automatic lubricating system, before operating the tool, add a few drops of Pneumatic Tool Oil to the air-line connection. Add more after each hour of constant using.
- Do not exceed maximum air pressure of 90 PSI/ 6,2 bar or as stated on tool nameplate.

LUBRICATION & MAINTENANCE

Lubricate the tool daily with a high grade of air tool oil. If no air line oiler is used, run a teaspoon of oil through the tool.
The oil can be squirted into the tool air inlet, or into the hose at the nearest connection to the air supply, prior to operating the tool.
A rust inhibitive oil is acceptable for air tools.

OPERATING INSTRUCTIONS

ONLY use accessories recommended by Polar Tools. Check the position of the reversing mechanism before operating the tool so as to be aware of the direction of rotation when operating.
Before switching on the tool, make sure that the grinding stone or rotating file is correctly assembled and properly tightened.
Assembly of the grinding stone/ rotating file: The die grinder must be disconnected from the compressed air supply.
Loosen the collet, then put the shank of grinding stone or rotating file in the collet as deep as possible.
Tighten it securely use the two wrenches included with the grinder.

PARTS NO.	DESCRIPTION
P6110-1000-01	Motor Housing
P6110-1000-02	Decorating Ring
P6110-1000-03	Air Inlet
P6110-1000-04	Throttle Lever
P6110-1000-05	Valve Shaft
P6110-1000-06	O-Ring (Ø 4.8 x Ø 2.2) •
P6110-1000-07	O-Ring (Ø 11.8 x 2.4) •
P6110-1000-08	Spring •
P6110-1000-09	O-Ring (Ø 40 x Ø2) •
P6110-1000-10	Plug
P6110-1000-11	Diffuser
P6110-1000-12	Rotor Bushing ◦
P6110-1100-13	Clamp Nut
P6110-1000-14	Rear End Plate
P6110-1000-15	Rotor
P6110-1000-16	Rotor Blade (4) •
P6110-1000-17	Ball Bearing (626zz)
P6110-1000-18	Cylinder ◦
P6110-1000-19	Front End Plate
P6110-1000-20	Spring Pin (3) - (Ø 2.5 x 6L) •
P6110-1000-21	Ball Bearing (3) (6000zz)
P6110-1100-22	Collet Holder
P6110-1000-23	Collet (1/4")
P6110-1000-23B	Collet (6 mm) ◦
P6110-1000-23C	Collet (8 mm)
P6110-1000-24	Collet Nut ◦
P6110-1000-25	Spring Pin (Ø 3 x 24L)
P6110-1000-26	Spring Pin (Ø 2 x 16L)
P6110-1000-27	Spring
P6110-1000-28	Safety Bar
P6110-1000-29	O-Ring (Ø 31.5 x Ø2) •
P6110-1000-30	O-Ring (Ø 35.5 x Ø2) •
P6110-1000-31	Grip
P6110-1100-32	Lock Nut
P6110-1100-33	Extension Bar
P6110-1100-34	Spanner (2)
P6110-1000-35	Screw (M4 x 8L)
P6110-1000-50	• Service Kit
P6110-1000-51	◦ Rebuilt Kit

EXTENDED DIE GRINDER

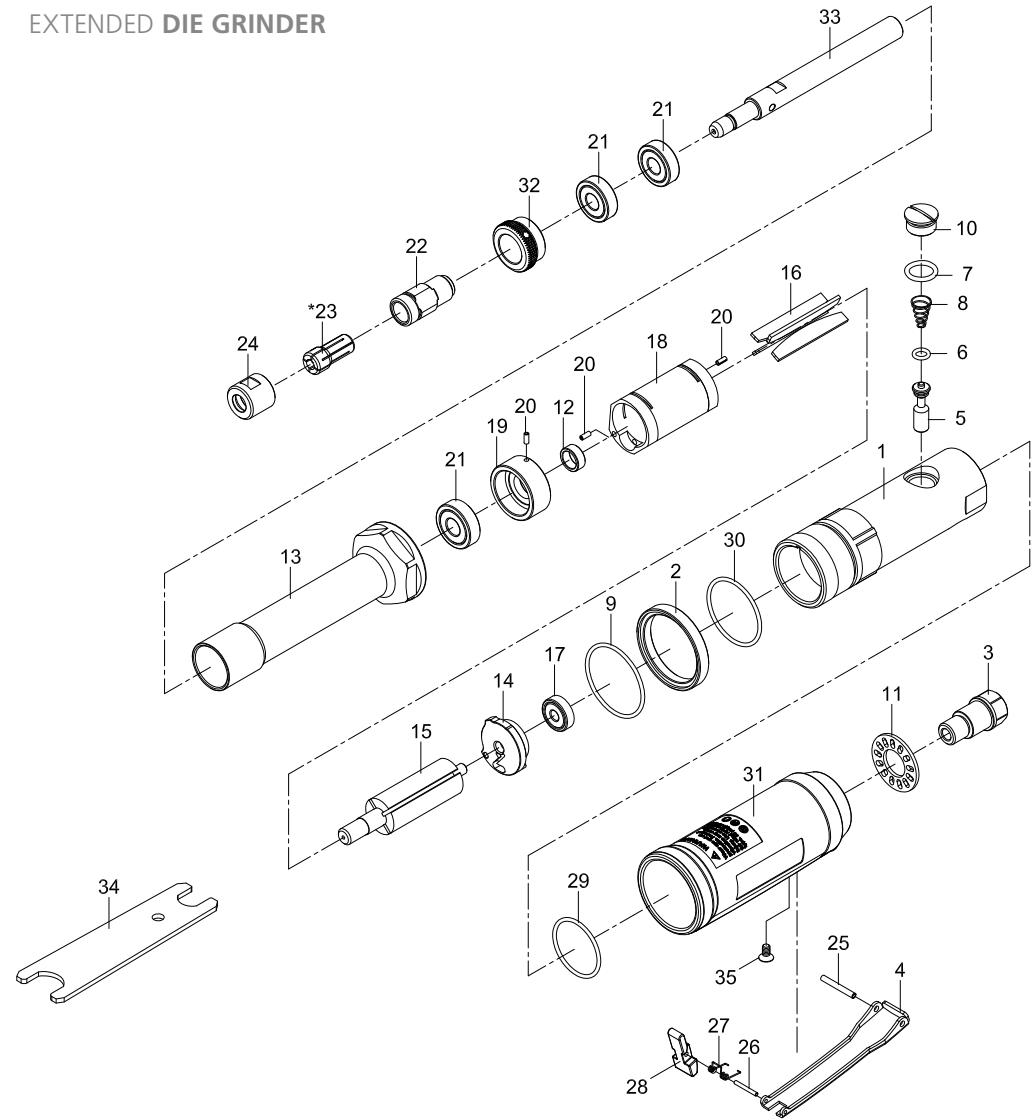

TECHNICAL SPECIFICATION

PRODUCT TYPE		MODEL: 6110-1100	
Extended die grinder		FREE SPEED	22.000 RPM
HOSE SIZE:	3/8" (10 mm)	WEIGHT:	1.2 Kg
COLLET SIZE:	1/4" (6 mm)	AIR PRESSURE:	6,2 Bar (90 P.S.I.)
AIR INLET:	1/4" NPT	HORSEPOWER:	1 HP
		AVERAGE AIR CONSUMPTION:	150 L/Min (5.3 CFM)