

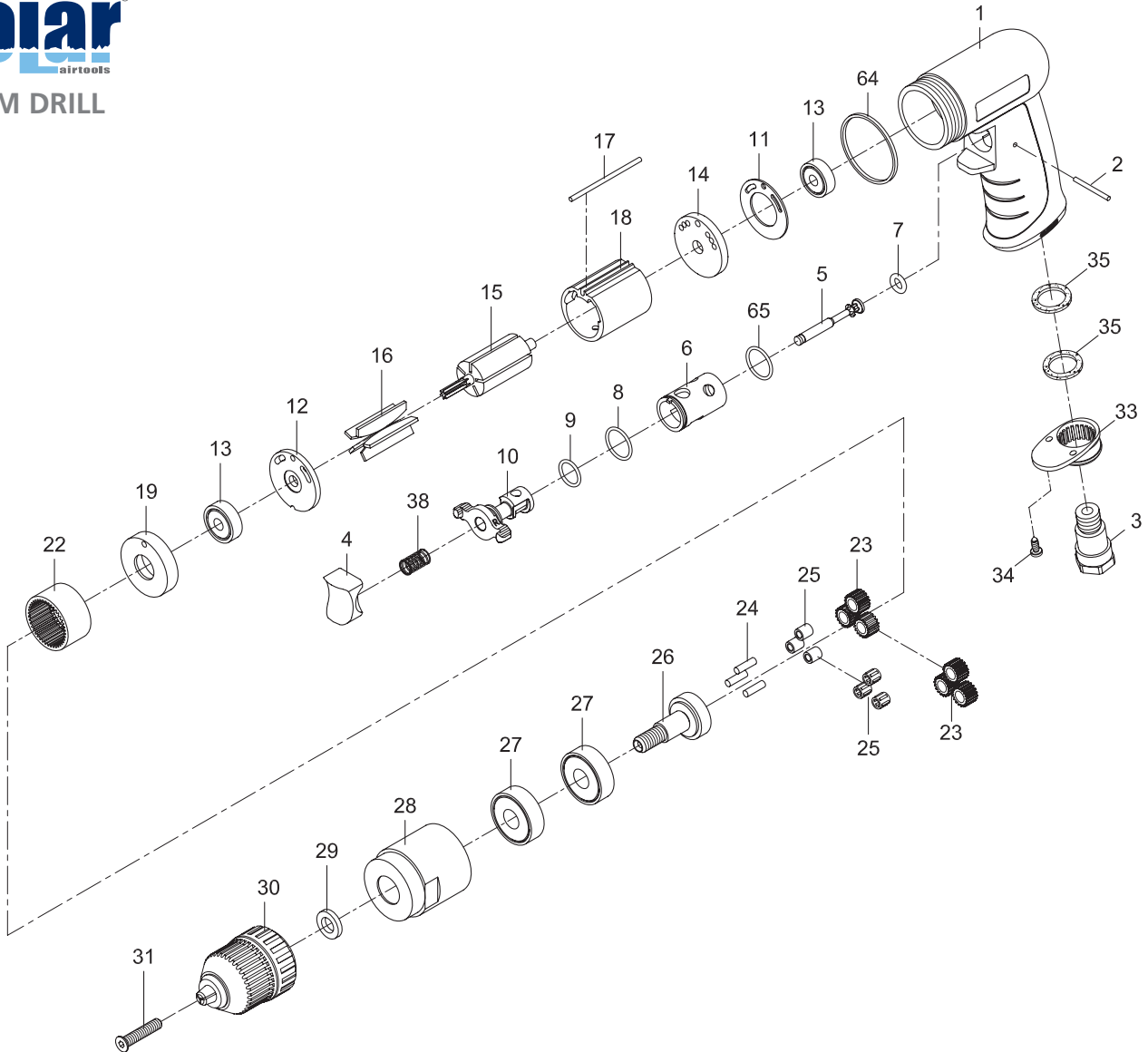

10 MM DRILL



PARTS NO.	DESCRIPTION	PARTS NO.	DESCRIPTION	PARTS NO.	DESCRIPTION
P6130-0010-01	Motor Housing	P6130-0010-14	Rear End Plate ◯	P6130-0010-29	Washer
P6130-0010-02	Pin (2,5 x 26,8)	P6130-0010-15	Rotor	P6130-0010-30	Keyless Chuck (10 mm)
P6130-0010-03	Air Inlet	P6130-0010-16	Rotor Blade (5) ●	P6130-0010-31	Screw (M5 x 25)
P6130-0010-04	Trigger	P6130-0010-17	Pin (2,5 x 57) ◯	P6130-0010-33	Exhaust Diffuser
P6130-0010-05	Valve Stem	P6130-0010-18	Cylinder ◯	P6130-0010-34	Screw (2) (TS2,9)
P6130-0010-06	Valve Bushing	P6130-0010-19	Front End Plate ◯	P6130-0010-35	Damping Material (2)
P6130-0010-07	O-Ring (4,5 x 2,5) ●	P6130-0010-22	Internal Gear	P6130-0010-38	Valve Spring
P6130-0010-08	O-Ring (15,5 x 1,5) ●	P6130-0010-23	Planet Gear (3) ◯	P6130-0010-64	Decoration Ring
P6130-0010-09	O-Ring (12 x 1,6) ●	P6130-0010-24	Pin (3) (4 x 13,8)	P6130-0010-65	O-Ring (15,7 x 1,7)
P6130-0010-10	Reverse Lever	P6130-0010-25	Needle Bearing (3) (4 x 7 x 8) ◯	P6130-0010-70	● Service Kit
P6130-0010-11	Motor Gasket ●	P6130-0010-26	Work Spindle	P6130-0010-71	○ Rebuilt Kit
P6130-0010-12	End Plate	P6130-0010-27	Ball Bearing (2) (6201z)		
P6130-0010-13	Ball Bearing (2) (626zz)	P6130-0010-28	Clamp Nut		

TECHNICAL SPECIFICATION

PRODUCT TYPE 10 mm Drill		MODEL: 6130-0010
FREE SPEED: 1.800 RPM	AIR INLET: 1/4" NPT	AVERAGE AIR CONSUMPTION: 113 L/Min (4 CFM)
CHUCK SIZE: 3/8"(10 mm)	HOSE SIZE: 3/8" (10 mm)	WEIGHT: 1,1 Kg
SPINDLE THREAD: 3/8"-24	AIR PRESSURE: 6,2 Bar (90 P.S.I.)	

