

AWILCO

INTELLIGENT BATTERY CHARGER

AW019625A

USER MANUAL



Please be sure to read and save the entire manual before using the energy system. Misuse may result in damage to the unit and/or cause harm or serious injury.

**PLEASE KEEP THE MANUAL
FOR FUTURE REFERENCE**

SERVICE CONTACT INFORMATION

Email: mail@awilco.dk

Phone: +45 56 56 54 00

Web: awilco.dk

1 SAFETY PRECAUTIONS

⚠ WARNING! To avoid any personal injury, please read the safety instructions below.

- It is best to have professional guidance when installing and using the charger. People with physical disabilities, visual impairments and olfactory impairments (including children) should not use this device. Children should be supervised to ensure they do not play with battery chargers.
- Do not disassemble or modify the charger, otherwise it will cause a safety accident.
- This charger is only suitable for battery types listed in the manual. Do not use it for other purposes.
- When charging, please select the charging procedure applicable to the auxiliary battery. If you choose the wrong charging procedure, it may cause certain damage to your auxiliary battery, and even cause safety accidents in serious cases. If you are not sure what kind of charging procedure you should choose, please consult relevant professionals.
- Please use the fuses and wires recommended in the instruction manual, otherwise it may damage the product and cause serious safety accidents.
- NEVER smoke or allow a spark or flame in vicinity of battery or engine. This may cause the battery to explode.

2 PRODUCT FUNCTIONS

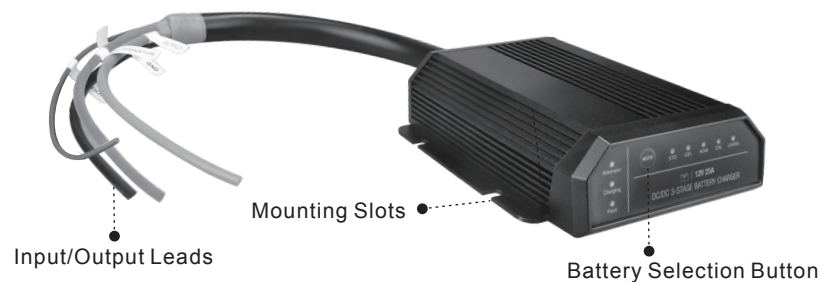

The DC25A charger suits for 12V lead acid batteries and 12V LiFePO4 batteries. It is workable for both 12V alternators and 24V alternators. The high power density design concept ensures the charger has excellent efficiency, and the ultra-thin size is suitable for limited installation space. It's work in some harsh environments, which is built very common for refitted off-road vehicles and touring cars.

- Compatible for multi battery types
- Efficiency up to 95%
- Excellent performance in harsh environments
- IP66, resistant to dust, water and shock damage
- Smart alternator compatible
- Smart protections including Low-voltage, Over-voltage, Over-Temperature and reverse polarity

2.1 Display Panel

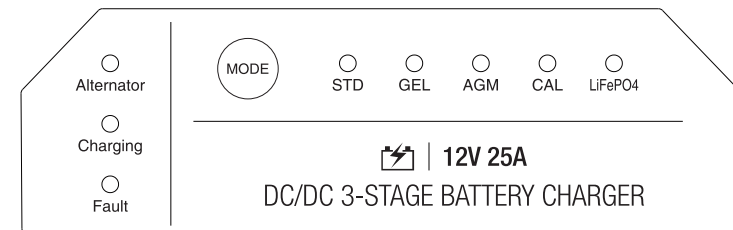

2.2 LED Charge Indicator

Charging	Alternator	Battery Type LED	Charging Stage
Short flash	Solid GREEN	Solid GREEN	Bulk or Absorption
Long flash	Solid GREEN	Solid GREEN	Float

2.3 Fault LED Indicators

Alternator LED	Battery Type LED	Fault LED	Trouble	Solution
Solid GREEN	Solid GREEN		Low voltage detected at Alternator input	Check battery voltage
	GREEN Flashing	Solid RED	Battery < 4V or overvoltage detected at output	Check auxiliary battery voltage & cable connections
GREEN Flashing		Solid RED	High voltage detected at Alternator input	Check battery voltage
		Solid RED	Over temperature	Let the unit cool down for some time or get better ventilation

3 THE INSTALLATION

3.1 Selection of Installation Location

The DC25A charger is designed for a variety of installation environments, including chassis rail, engine cabin, driver cabin and etc. DC25A charger uses the advanced technology so that the product can work stably in the shaking, wet, dusty and muddy environment. The DC25A charger is as thin as 39mm and it can work up to 80°C, so it can be installed in the engine cabin. But please note that if you want to get a higher charging efficiency, you should try to get it stay away from the high-temperature parts of the engine cabin. When installing, the charger should be put closely to the auxiliary battery and please select the proper charging mode. After selecting the installation position, please fix the charger with screws.

3.2 Selection of Conductor

The DC25A charger wire may be not long enough for installation. So if you need to extend the wire, please check the below table with suggested wire sizes. You can choose wires that are equal to or larger than this size.

ALTERNATOR (Yellow) OUTPUT (Red) GND (Black)	<5m	<10m
	13mm ² (10AWG)	20mm ² (8AWG)
IGNITION (Blue)	0.5mm ² (20AWG)	0.5mm ² (20AWG)

It is very important that the extension wire and the reserved wire are well connected, and the low conduction impedance can ensure the stable and reliable operation of the product. It is recommended to use Butt Splice Connectors. After completion, heat shrinkable tubing must be used for insulation to prevent short circuits.

Butt splice connector	BN8 for 10-8AWG	
-----------------------	-----------------	---

3.3 Wiring Steps

In order to prevent accidental short circuit during installation, it is recommended to turn off the car during the installation and the negative pole of the starter battery should be disconnected. Please note that vehicle power down may result in loss of memory data. If the installation is powered on, please proceed with caution.

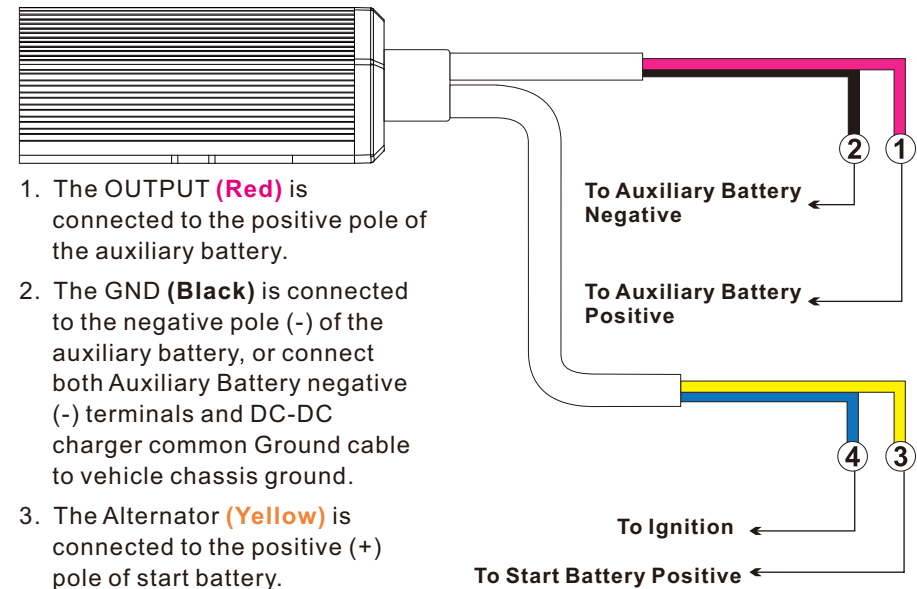

- The IGNITION (Blue) is connected or not depends on the type of vehicle alternator. For standard alternators, just leave it alone. Pay attention to insulation protection. For smart alternators, please connect to the ignition terminal of the vehicle. You can usually find such a connection point in the car fuse box. When the car is started, the terminal is power on. When the car is turned off, the terminal is power off.
- Restore the negative connection of the battery. If all are ready, the charger will start to work.

3.4 Typical Setup

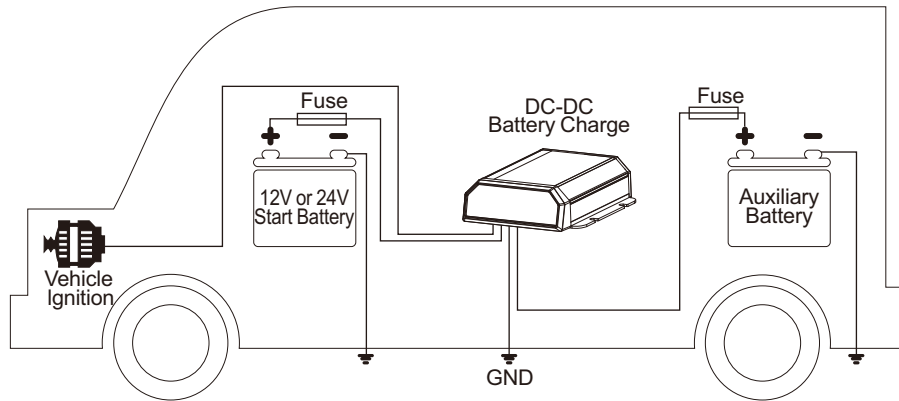

3.5 Fuse Specification

All recommended fuses should be connected in series in circuit. Bolt down fuses are preferred because they ensure a low resistance connection. Blade type fuses are not recommended as they can result in a high resistance connection which causes excess heat and may damage the fuse holder and/or the wiring. Self-resetting circuit breakers are not recommended as they may trip prematurely due to the heat generated by the current flowing through the wires.

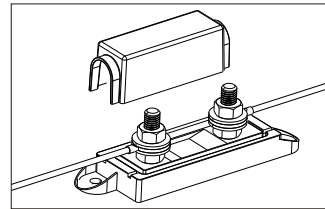

ALTERNATOR (Yellow) OUTPUT (Red)	40A
IGNITION (Blue)	3A

4 SPECIFICATION

Operating Conditions					
Vehicle Input Voltage	9-32V				
Max Input Current	25A				
Input Fuse Rating	40A				
Continuous Output Current	25A				
Output Fuse Rating	40A				
Minimum Start Voltage	4V				
Standby Current	<10 mA				
Battery Type	STD, GEL, AGM, CALCIUM & LiFePO4				
Operating Temperature	-20°C to +80°C				
IP Rating	IP66				
Weight	670g				
Dimensions	150x127x39 mm				
Charge Control					
Charge Type	3 Stage				
Charging Profile	STD	GEL	AGM	Calcium	LiFePO4
Maximum Voltage	14.4V	14.1V	14.7V	15.3V	14.5V
Float Voltage	13.4V	13.5V	13.4V	13.6V	
Operating Mode					
Input	Turn On		Turn Off		
12V Standard Alternator	>13.2V		<12.8V		
24V Standard Alternator	>26.2V		<25.6V		
12V Smart Alternator	>12.0V		<11.8V		
24V Smart Alternator	>24.0V		<23.6V		



AWILCO

FLEXIBLE POWER SOLUTIONS