

## 1.1.1 Usermanual – Entiffic Air - Methanol - ENG

Doc. no. : 01

Revision : Rev B

Page : 1 of 15

Author : NW

Approved by :

Rev. Date : 5/10-2023

# Entiffic AIR Brugermanual - Methanol version



Improper installation of Entiffic AIR can cause fire, leakage of harmful carbon monoxide that can cause serious injury or death.

To install and maintain an Entiffic AIR system, professional expertise and technical documentation is necessary. Special tools and equipment may also be required.

NEVER attempt to install or maintain an Entiffic AIR heating system without prior training and experience with Entiffic heating products.

Carefully follow all instructions from Entiffic ApS and this installation guide.

Entiffic declines any liability for damage or problems caused by the product if it is installed by untrained personnel or against the instructions in the installation manual.

<b>1.1.1 Usermanual – Entiffic Air - Methanol - ENG</b>			
Doc. no. : 01	Revision : Rev B	Page : 2 of 15	
Author : NW	Approved by :	Rev. Date : 5/10-2023	

# 1 Table of content

1	Table of content .....	2
2	First start .....	3
3	Operating the heater.....	3
4	3.1 Operating panel.....	3
5	Installation.....	4
5.1	Max lengths on airtubes.....	5
5.2	Measuring room temperature .....	7
5.3	Fuel .....	7
5.4	Exhaust .....	9
5.5	Airinlet for combustionair .....	9
5.6	-.Electrical installation .....	9
5.7	Additional on/off switch (accessory, purchased separately) .....	12
6	Drilling template and example/measurement of gasket between mounting plate and body.....	12
7	Errorcodes .....	13
8	Technical data .....	14

## 1.1.1 Usermanual – Entiffic Air - Methanol - ENG

Doc. no. : 01

Revision : Rev B

Page : 3 of 15

Author : NW

Approved by :

Rev. Date : 5/10-2023

## 2 First start

- Connect the heater to a fully charged 12V Battery – pay attention to correct polarity.
- Bleed the fuellines before the first start. At a minimum, the fule line between the tank and the pump must be filled with fuel before attempting to starte the heater.
- The heater may fail during the first start due to lack of fuel. Wait for the cooldown process to be completed (both fans have some to a complete stop) , before resetting the errorcode and restart of the heater. This process may need to be repeated several times untill all air is removed om the entire fuleline

## 3 Operating the heater

Entiffic Air is a self-powered heater designed to work independently, connected only to the supply of methanol and a 12V battery. When the operating temperature is reached, the Entiffic Air supplies a surplus of power to charge the connected battery.

### 4 3.1 Operating panel



Operating panel



Heat button: 1) temperature controlled heating.

- To start the heater: Press for 2 seconds (long press) heating button 1. If the room temperature measured internally in the control panel is higher than the heater's set/desired room temperature, the yellow LED will light up and the heater will not start. The heat remains in stand-by, the yellow LED lights up, and when the measured room temperature falls below the set temperature, the heater will start automatically.
- When startup is activated, the green LED flashes. When the normal operating mode is reached, the green LED lights up continuously. When the temperature set point is reached, the heater switches off automatically. During shutdown (cool down), the green LED flashes. After shutdown, the yellow LED lights up, indicating that the heater is still in standby and waiting for automatic start to be activated.
- A long 2 sec. Pressing fan button 2 automatically deactivates heating mode and activates idle mode.

Rotary knob: The rotary knob (3) continuously adjusts the desired temperature setting between 0°C (fully counter-clockwise) and 30°C (fully clockwise).

## 1.1.1 Usermanual – Entiffic Air - Methanol - ENG

Doc. no. : 01	Revision : Rev B	Page : 4 of 15
Author : NW	Approved by :	Rev. Date : 5/10-2023



Fan button 2)

- Can be used if a fan/ventilating function is desired. The fan in the heater runs, but no heat is produced. Note that the heater in fan mode does not charge the connected battery.

- If the heater is in fault mode - red diode flashes - you must use button 1 to reset the fault.

- If the heater is not in error mode, button 1 can be used to adjust the heater's output. There are 5 power settings (see specifications in the picture above) corresponding to five different fuel consumptions: 0.12 litres/hour; 0.14 l/h; 0.16 l/h; 0.18 l/h; 0.20 l/h. Follow the sequence below to adjust the power setting when the heater is in normal operation:

1. Press fan button 1. This disables the thermostat function. Yellow LED is on.
2. Turn the knob to the desired power setting. Yellow LED is lit steadily.
3. Press fan button 1. This selects the desired power setting. Yellow LED flashes.
4. Turn the knob back to the MAX temperature setting point (far right/clockwise). The yellow LED flashes.
5. Press fan button 1. This reactivates the thermostat function. Yellow LED is off.

### LED indications

#### GREEN LED:

Steady light when the heater is heating up and the start-up sequence is complete.

Blinks more on than off, indicating the heater is in start-up mode.

Flashes more off than indicating the heater is in shutdown mode.

#### YELLOW LED:

LED lights up solid:

- o The heater is on standby and waits for the room temperature to drop below the set temperature.
- o The heater is running in fan mode (air is circulated – heater does not produce heat).

#### GREEN + YELLOW LED are ON

o The heater is in service mode

o Signals an error if the red LED also flashes

#### RED LED:

- Indicates that there is a fault that need to be attended to. Search for help in the error code overview or contact the dealer/installer.

## 5 Installation

Important - before installation:

- Pay attention to the applicable regulations for the installation of heaters before proceeding with the installation. Note: The heater is not approved for use in hazardous areas.

- The heater is approved for installation in vehicles in vehicle categories M, N and O and as a space heater in containers, cabins, boats, etc.

- When installing in wheeled vehicles, the latest statutory regulation of ECE / UN R122 must be read, understood and followed.

- IMPORTANT when connecting to a battery: The heater must be connected to a line that is connected directly to a battery and insured with a minimum of 10A. Avoid connecting via a relay or other indirect switch as this may cause the heater to malfunction.

Installation and dimensions of the heater

Installation dimensions and space requirements are shown in Figure 1.

- The heater is mounted to a solid surface/body with 4xM6 bolts through the mounting plate - 6.

## 1.1.1 Usermanual – Entiffic Air - Methanol - ENG

Doc. no. : 01	Revision : Rev B	Page : 5 of 15
Author : NW	Approved by :	Rev. Date : 5/10-2023

- A gasket must be fitted under the interface plate pos 6 to prevent exhaust gas from entering the room where the heater is installed. Make sure the seal can withstand 230 C.
- The heater must be installed horizontally with a maximum deviation of 5 degrees from horizontal.
- It must be checked that the heater's cabinet/housing is not in contact with any external parts.
- Ensure that the heater is mounted in a position where it is protected from water and splashes. The heater must be installed in such a way that no water can reach the heater.
- The openings for the combustion air intake, the exhaust pipe and the fuel pipe must be sealed if the heater is installed in the same room as it is to heat. The exhaust must be sealed with fire-retardant materials.

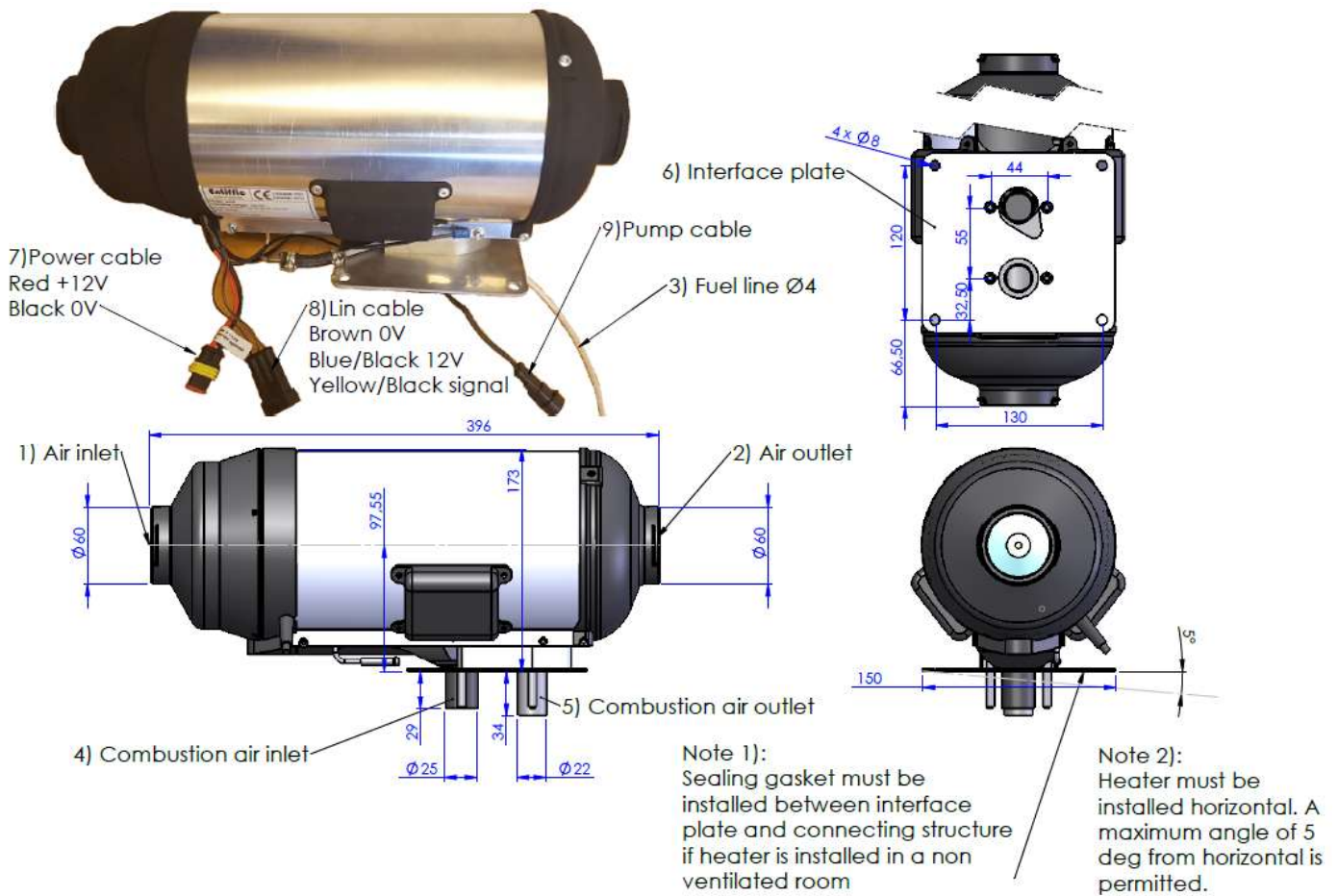

Figure 1: Heater dimensions

### 5.1 Max lengths on airtubes

Max allowed length on Ø60 tube, inlet/outlet combined	10m
Max allowed length on Ø60 tube, inlet or outlet	5m
Max accumulated bends on Ø60 tube	540 deg.
Max no of joints on Ø60 tube	3
Diameter on circulated inlet / outlet tube	60mm

Table 1

## 1.1.1 Usermanual – Entiffic Air - Methanol - ENG

Doc. no. : 01

Revision : Rev B

Page : 6 of 15

Author : NW

Approved by :

Rev. Date : 5/10-2023

Note: Be aware that other connectors in the air pipes will reduce the air flow drastically. (some pieces can increase resistance comparable to 5m air hose.)

Air duct insulation is a very cheap and effective way to increase heating efficiency.

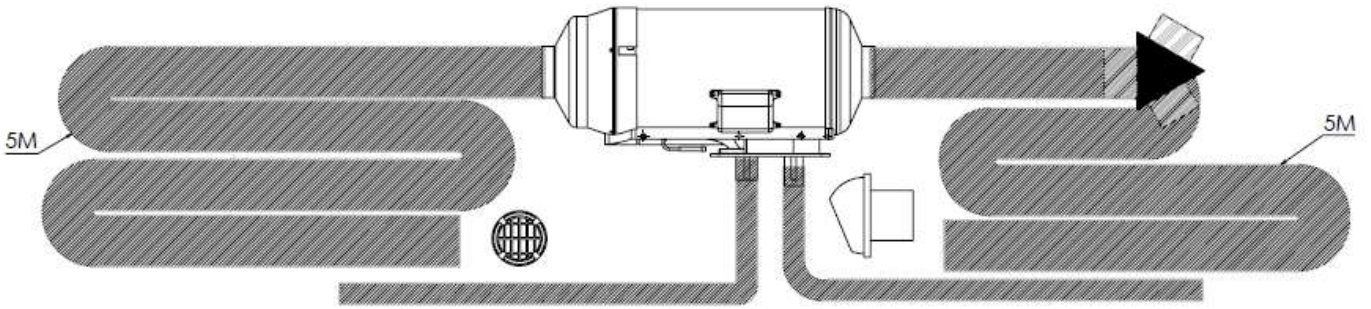

Figure 2: Example of heater installed with a maximum hose as listed in Table 1. Except that the heater is shown with 1080 degrees of bend in the picture and only 540 degrees is allowed.

If necessary, a grill is fitted to prevent leaves and other unwanted objects to enter the heating unit.



Figur 32 – Example of grill for fresh air inlet

Important:

- Only materials that can permanently withstand temperatures of at least 150°C can be used for the hot air outlet hose. The hot air opening must be placed in such a way that the air is not blown directly on surrounding parts that cannot withstand the heat, and in a position that ensures a free flow of air at all times. The air outlet and intake openings must always be installed in a position that makes them unlikely to be blocked by objects and at least 20 cm from the nearest surface.
- The hot air pipes must be secured at all connection points.
- If the heater is used without an air inlet hose, an inlet grille must be fitted to the heater
- If the heater is used together with another heating system, special attention must be paid to ensure that the system works.

<b>1.1.1 Usermanual – Entiffic Air - Methanol - ENG</b>			
Doc. no. : 01	Revision : Rev B	Page : 7 of 15	
Author : NW	Approved by :	Rev. Date : 5/10-2023	

- Make sure to keep a suitable distance between the intake and exhaust ducts when recycling heated air.

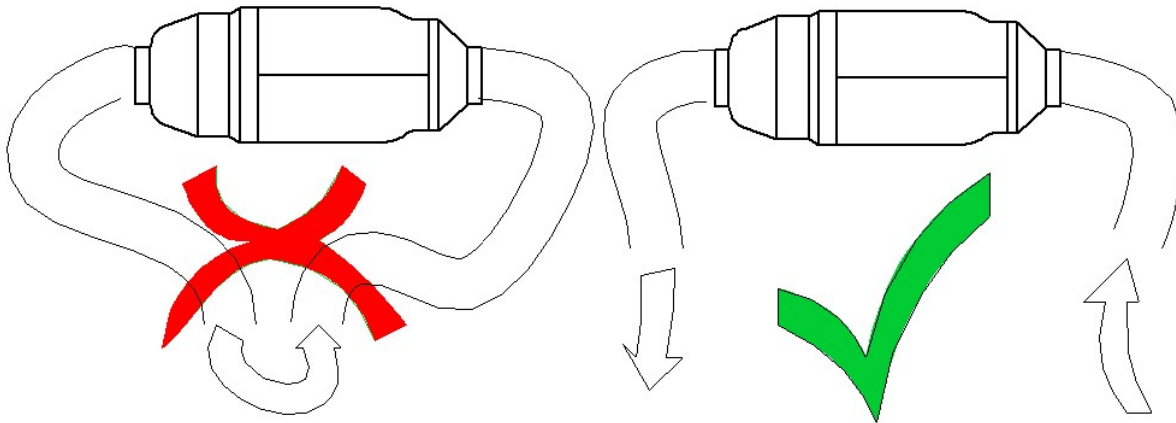

Figure 3

## 5.2 Measuring room temperature

The heater's control panel is supplied with a built-in temperature sensor. If the control unit is mounted in a place that is not suitable for measuring the temperature, an additional temperature sensor can be purchased and installed for optimal temperature measurement.

The control unit / temperature sensor should not be installed:

- In areas other hot air flow may occur (from the vehicle's own heating system or directly in the hot air from the heater).
- in direct sunlight (e.g. on the dashboard).
- behind curtains or similar.



Image 4: Operating panel

## 5.3 Fuel

The heater must be connected to the supplied pump. The pump is mounted on a holder for a methanol canister. The methanol container used must only be of the EFOY M5 or EFOY M10 type.

It is not permitted to refill the containers. If methanol of a different type is used in EFOY, the warranty is void. The methanol container must be fixed in the holder with the supplied strap, which fits both M5 and M10 containers.

The holder for methanol must be fixed with 4 bolts or screws to the base, in the immediate vicinity of the heater.



## 1.1.1 Usermanual – Entiffic Air - Methanol - ENG

Doc. no. : 01	Revision : Rev B	Page : 8 of 15
Author : NW	Approved by :	Rev. Date : 5/10-2023

Figure 7

Maximum length of fuel hose between pump and heater A 40 cm hose is included.	≤ 2 Meters
Maximum height difference between pump and heater	Max ± 1 Meter

Table 2

Figure 5 shows maximum lengths for fuel hose installation

For ADR only: The statutory regulation of ADR governing fuel tanks must be complied with.

The Entiffic Air standard fuel line is a rubber hose ECO 1 TSBE, with inner  $\varnothing$ : 5 mm and outer  $\varnothing$ : 10 mm.

Important installation instructions:

- The connection points along the fuel hose must be 100% airtight, ensure that the fuel hose / pipe and the joint / hose are tight together and clamps are used to secure the connection.

This prevents air from getting stuck inside the hose or pump.

- The fuel pump and fuel hoses must not be installed within reach of radiant heat from hot parts. A heat shield should be used to protect the parts if necessary.



Figur 8 sikring af brændstofslange med spændebånd



## 1.1.1 Usermanual – Entiffic Air - Methanol - ENG

Doc. no. : 01

Revision : Rev B

Page : 9 of 15

Author : NW

Approved by :

Rev. Date : 5/10-2023

### 5.4 Exhaust

- Installation of the exhaust pipe must prevent emissions from the heater from entering the heated space through fans, fresh air intakes or open windows.
- The exhaust must be positioned so that no dirt, mud or water covers the exhaust pipe. Installation of a gooseneck / water trap / muffler is required for installation on boats.
- The last 10 cm of the exhaust hose must be installed at a maximum of 5 ° from vertical.
- The sum of all bends must be less than 360 degrees.
- Make sure that the exhaust only affects materials that can withstand heating of 350 ° C

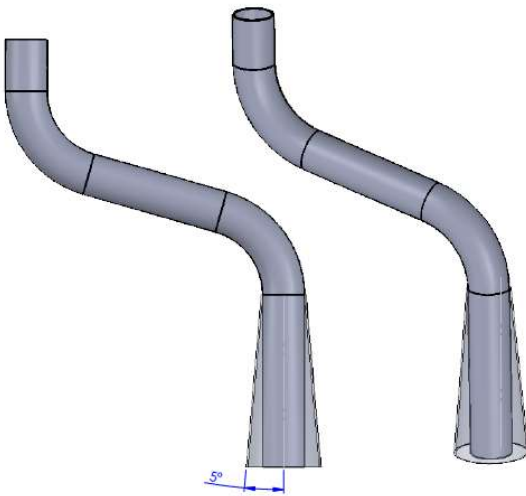

Figur 9 Example of exhaust pipe and maximum deviation from vertical

### 5.5 Airinlet for combustionair

- The air for the heater's combustion chamber must not be taken from the passenger compartment or a room that is not ventilated.
- The air intake must be positioned or protected in such a way that blocking of snow, water, tools or other unintended foreign objects / materials is not possible.
- The air intake must be positioned in a way that prevents wind from affecting the air flow into the air intake pipe

### 5.6 -.Electrical installation

- The power cable for the installation kit is 4.9 m long. Red wire is for + 12V. Black wire is 0V.
- Installation set Lin-bus cable is 4.6 m long.
- Installation kit pump cable is 6 m long.
- A 15-amp fuse must be installed between the battery and the heater
- Cables must be installed in a way that prevents mechanical stress on connectors and cables.
- Be aware that loose cables can be exposed to mechanical stress due to vibrations and consequently cause errors and/or damage to the heater and surroundings.

# 1.1.1 Usermanual – Entiffic Air - Methanol - ENG

Doc. no. : 01	Revision : Rev B	Page : 10 of 15
Author : NW	Approved by :	Rev. Date : 5/10-2023

- Do not subject the wire connections to extreme bends.

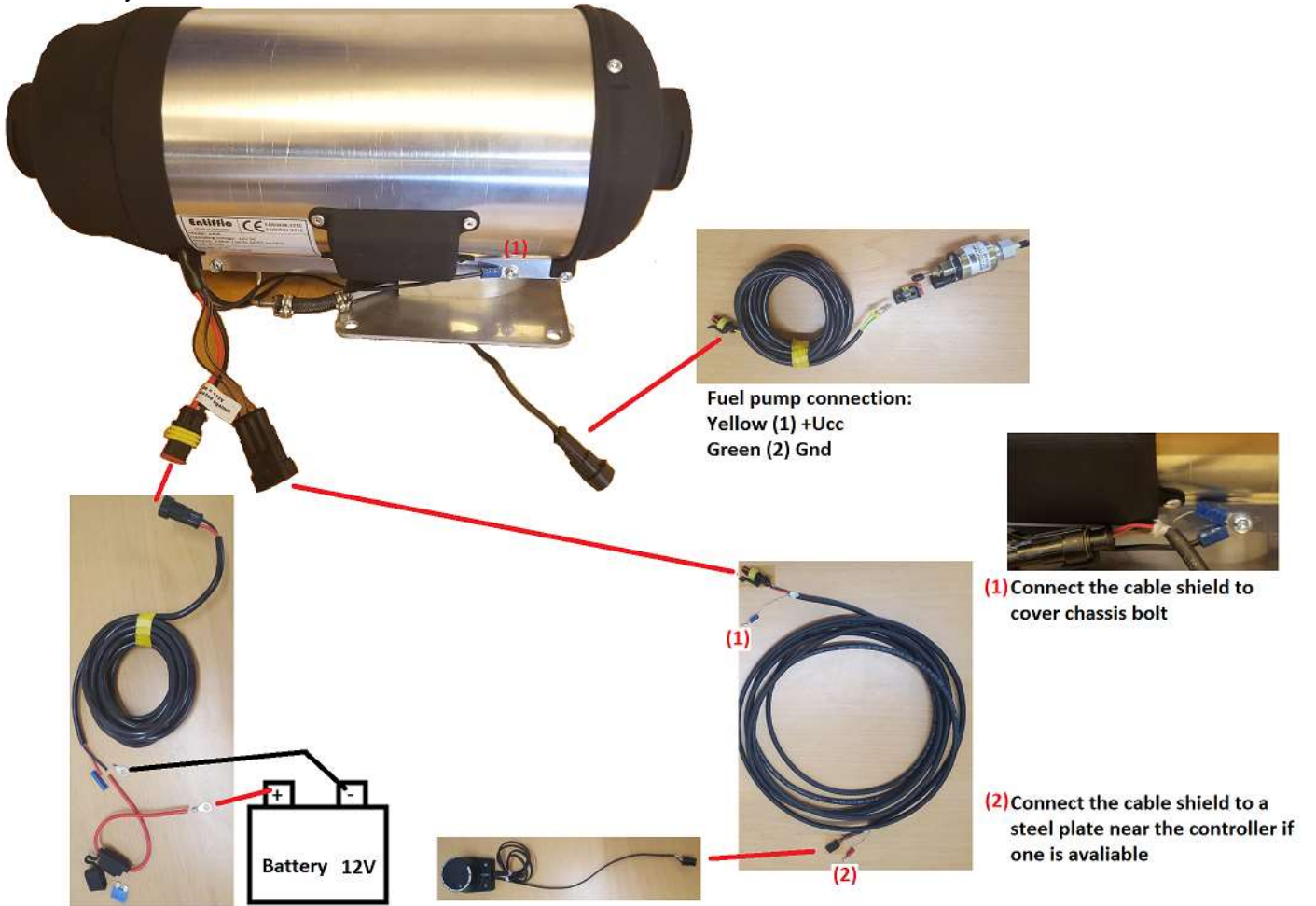

Figure 10 Elektrical connections

## 1.1.1 Usermanual – Entiffic Air - Methanol - ENG

Doc. no. : 01

Revision : Rev B

Page : 11 of 15

Author : NW

Approved by :

Rev. Date : 5/10-2023

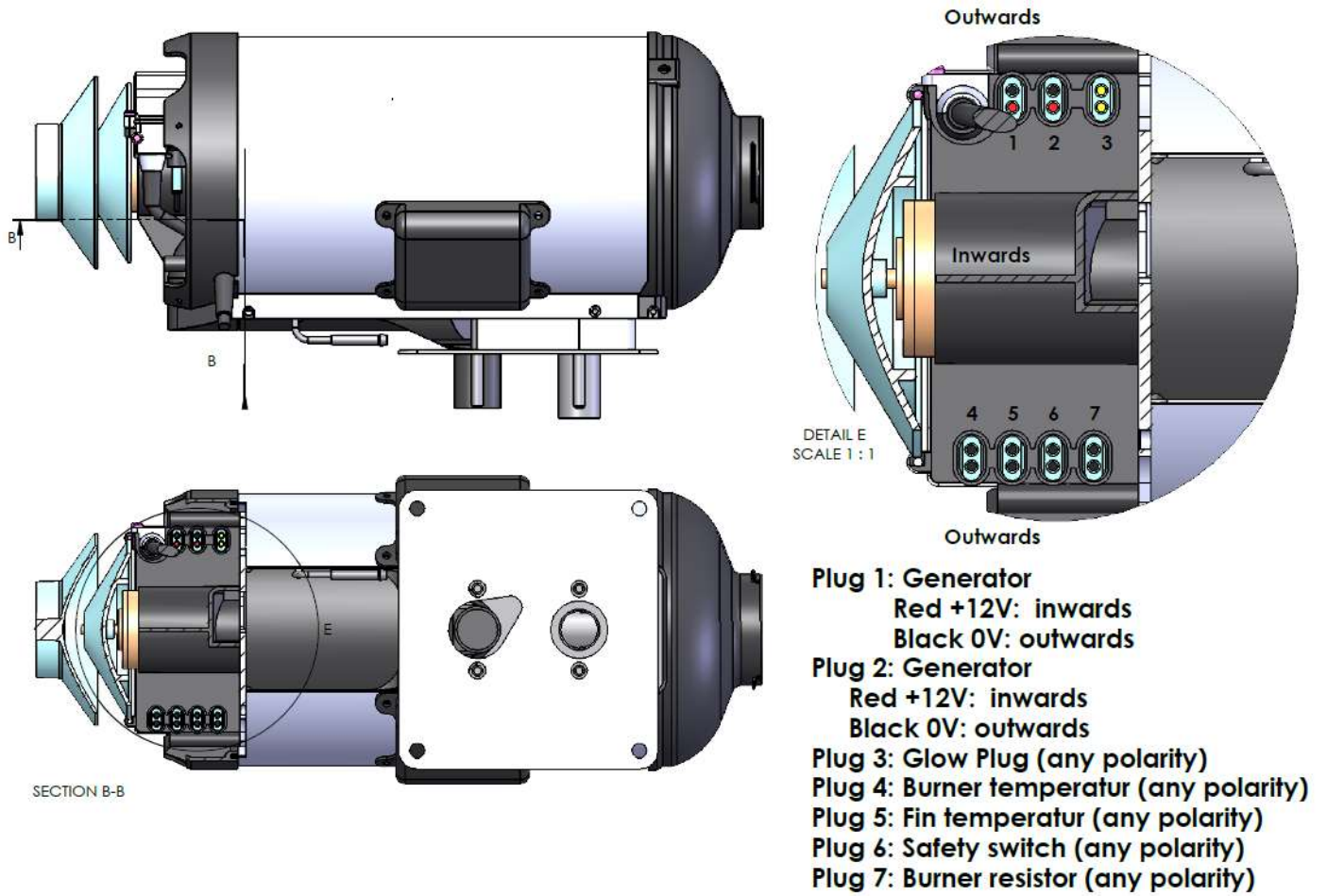

Figure 11 Shows the interior plug and their position in the heater.

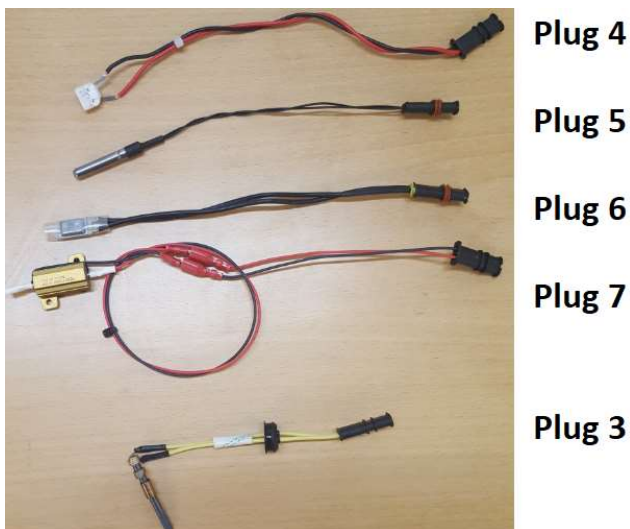

Figure 12 Shows the interior plugs except the generator plugs

<b>1.1.1 Usermanual – Entiffic Air - Methanol - ENG</b>			
Doc. no. : 01	Revision : Rev B	Page : 12 of 15	
Author : NW	Approved by :	Rev. Date : 5/10-2023	

### 5.7 Additional on/off switch (accessory, purchased separately)

It is possible to supply the heater with an additional / manual on/off switch.  
 It is necessary that the switch is of a type that can maintain a setting, as it is necessary to connect a wire with 12V+.

Note that the manual switch activates the same function in the heater as button "1" on the control panel. This means that the thermostat will send a signal to the heater when it is to be in operation/stand by.

#### Installation

On the control panel there are 2 wires with a red/white conductor and a small black 2 pole plug. Identify the 2-pin connector with the lock key as shown in the images below



Figure 13

Cut the white wire immediately behind the plug and connect the white wire to the outlet of the switch. Connect the other leg of the switch to 12V+

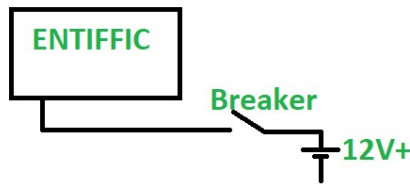

Figure 14

## 6 Drilling template and example/measurement of gasket between mounting plate and body.

- Gasket must close tightly around the heater pipe/line to ensure that exhaust gas does not draw back into the heated area. The gasket must be able to withstand temperatures of at least 230 oC.

Interface plate:

Eksample of gasket dimensions:

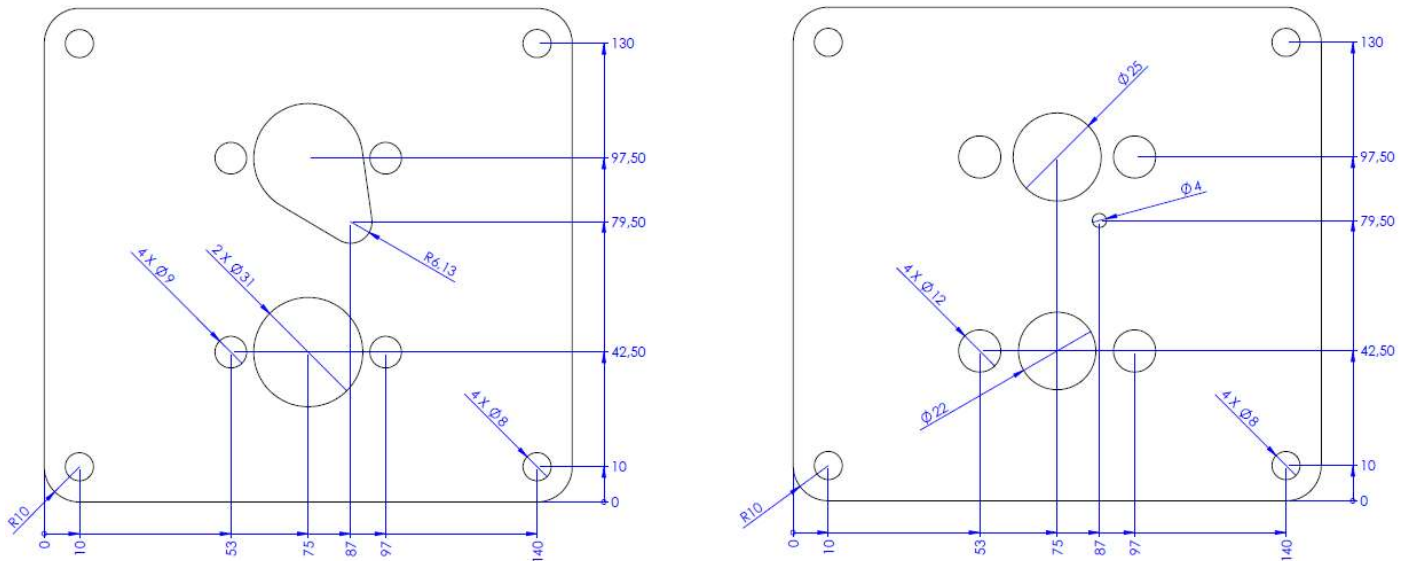

Figur 45: Dimensions of mounting plate and recommended dimensions of gasket.

<b>1.1.1 Usermanual – Entiffic Air - Methanol - ENG</b>			
Doc. no. : 01	Revision : Rev B	Page : 13 of 15	
Author : NW	Approved by :	Rev. Date : 5/10-2023	

## 7 Errorcodes

If an error occurs, the red LED flashes. The red LED indicates the error code with the number of flashes followed by a pause. The number of short red flashes in the pulsation determines the fault code.

Example: E09 corresponds to the red LED flashing 9 times, and E09 + Y corresponds to the yellow LED and the red LED flashing 9 times.

<b>Error Codes Table: according to prog 170</b>		
<b>ID</b>	<b>Error description</b>	<b>Possible reason and remedy</b>
<b>E02</b>	Internal temperature drops during startup	Check for air in the fuel supply, exhaust blocked or failure to install the exhaust
<b>E03</b>	Intern temperature falder under opstart - tidligt check	Internal temperature drops during startup - early check
<b>E04</b>	Internal temperature does not rise as expected during startup	Check for lack of fuel supply, defective fuel pump, combustion chamber clogged/sooted, correct position of burner cup, defective temperature gauge at the top of combustion chamber (must have an Ohm's resistance of $1050 \Omega \pm 50\Omega$ ), air in fuel supply, exhaust blocked or error in mounting the exhaust
<b>E05</b>	Sudden temperature drop during operation at normal operating temperature	Check if fuel pump delivers fuel. Check the temperature gauge at the top of the combustion chamber, air in the fuel supply, exhaust blocked or errors in the installation of the exhaust
<b>E06</b>	Internal temperature too low and falling during operation. Control takes place after 110 sec.	Check whether the fuel pump delivers fuel and check the temperature sensor at the top of the combustion chamber, air in the fuel supply, exhaust blocked or a fault in the installation of the exhaust.
<b>E07</b>	Internal temperature drops too fast during startup	Check the temperature gauge at the top of the combustion chamber, air in the fuel supply, faulty fuel pump, exhaust blocked or failure to install the exhaust
<b>E08</b>	Sudden temperature drop during operation at normal operating temperature	Check the temperature gauge at the top of the combustion chamber, air in the fuel supply/defective fuel pump, exhaust blocked or failure to install the exhaust
<b>E09</b>	No connection between control panel and heater	Check wiring and connection – could be a damaged wire/plug or incorrect plug termination. Another source of error can be EMC noise in the installation
<b>E02+Y</b>	Circulation fan error – Fan speed too low	Cirkulationsblæser til frisk luft er fysisk blokeret eller blæsermotor er defekt. Frossen kondensvand kan være en årsag til blokeret blæser
<b>E03+Y</b>	Burner fan error – fan speed too low	The burner fan is physically blocked or the fan motor is defective - contact an installer/dealer
<b>E04+Y</b>	Battery voltage below 10V	Check battery – cause may be bad/defective battery.
<b>E05+Y</b>	Too high temperature in heater	Check if the hot air outlet is blocked.

## 1.1.1 Usermanual – Entiffic Air - Methanol - ENG

Doc. no. : 01	Revision : Rev B	Page : 14 of 15
Author : NW	Approved by :	Rev. Date : 5/10-2023

<b>E06+Y</b>	For høj/varm temperatur konstateret	Heater is too hot and must complete cool down before restarting. Wait for fan to turn off, disconnect power, connect to power, reboot. If errors occur during operation, check combustion chamber for slag. If error occurs during startup: Check both temperature sensors. Must have a resistance of $1050\Omega \pm 50\Omega$ . If the sensors are OK, there is a fault on the print – have a fitter change the print.
<b>E07+Y</b>	Too high voltage on thermoelectric generator	Check the plug internally in the heater - contact a fitter/retailer
<b>E08+Y</b>	Glowplugfaliure	Contact installer/retailer
<b>E09+Y</b>	Connection between control panel and heater has been disconnected for too long	EMC noise in system, bad/defective connections, incorrect installation of connection cable/plug between heater and control panel.

If an error occurs, the heater automatically starts to cool down and stops operation. After complete shutdown, reset the heater by pressing button 1 once. **VERY IMPORTANT:** Always let the heater complete the cooling process. **NEVER** unplug the power while the heater is cooling down, as this can damage the heater's power generating element if it is too hot.

If an error code occurs, the following may cause the error or identify the cause of the error:

- Visually inspect the heater for any abnormalities and the smell of methanol or exhaust.
- Loose connection along the fuel line, air entering the system.
- Loose plug connection internally in the heater
- Loose connector connection externally. Battery, battery fuse, check connections, pump connection.
- Blockage of the combustion air intake or exhaust pipe opening.
- Temperature sensor defect.
- Overheating sensor disconnected, shorted or incorrectly installed
- Glow plug defective.
- Blower motor overloaded, blocked or defective.
- Error in the dosing pump.
- Low voltage <10.0 or High voltage > 16V, longer than 1 second
- Error on control panel
- Overheating due to incorrect installation
- Incorrect combustion air inlet and outlet

Contact an authorized installer if the heater continues to go into error mode.

## 8 Technical data

The technical data provided is based on an ambient temperature of 20°C.

- All components are designed for 12V.
- The methanol oil specified by the manufacturer according to EN590 must be used. Class EL fuel oil (not L fuel oil) can also be used if it complies with the normal quality available on the Western European markets according to DIN 51603 or EN ISO 3735 standards.
- If the fuel class is changed, ensure that the heater has been used until all fuel lines are filled with the new fuel class used.

## 1.1.1 Usermanual – Entiffic Air - Methanol - ENG

Doc. no. : 01	Revision : Rev B	Page : 15 of 15
Author : NW	Approved by :	Rev. Date : 5/10-2023

<b>Entiffic Air Methanol heater</b>	
<b>Fuel -40°C or varmer</b>	Methanol i beholdere EFOY M5 eller EFOY M10
<b>Voltage</b>	12V DC
<b>Heat output</b>	2 kW
<b>Warm air volume</b>	65 m3/hr
<b>Surplus electrical power for bat. charging</b>	10-12W
<b>Fuelconsumptin</b>	0,20 l/hr by min. output 0,40 l/hr by max output
<b>Operatingtemperaturerange</b>	-40°C - +28°C
<b>Storage temperaturesrange</b>	-40°C - +75°C
<b>Temp. range for ambient air for combustion</b>	-40°C - +30°C
<b>Recommended temp range for ambient air for heating</b>	0°C - +30°C
<b>Dimensions (L x B x H)</b>	400mm x 135mm x 175mm
<b>weight</b>	4,6 kg

ENTIFFIC ApS  
Yderholmvej 64  
4623 Lille Skensved  
Denmark  
[www.entiffic.com](http://www.entiffic.com)  
mail@entiffic.com